

2CCP SERIES

004796
Issue 1

Cable-Pull Safety Switch



APPLICATIONS

Long conveyor systems found in

- Warehouses and distribution centers
- Post and parcel facilities
- Food & beverage or pharmaceutical production

Large machinery found in

- Packaging equipment
- Assembly lines like automotive
- Woodworking and textiles



Industrial plants such as

- Cement and asphalt production
- Chemical processing
- Mining
- Power plants

VALUE PROPOSITION

The 2CCP, Honeywell's newest MICRO SWITCH Cable-Pull Safety Switch, provides an economical switching solution for an easily accessible emergency stop function along conveyors and machines. The 2CCP provides reliable performance, a highly configurable platform, easy installation, simplified maintenance, and faster equipment restart to meet the needs of a wide range of end-users.

HONEYWELL CABLE-PULL SWITCH PORTFOLIO

	2CCP	1CPS	2CPS
			
Key Features	<ul style="list-style-type: none"> Dual direction Improved design for LED and tension windows Updated design to easily and economically replace faceplate All options in one package size 	<ul style="list-style-type: none"> IP67 sealing Smaller footprint than dual direction Extra contact and connector options 	<ul style="list-style-type: none"> Dual direction IP67 sealing Large and robust die-cast aluminum housing
Options	<ul style="list-style-type: none"> Rear conduit port Dual, left, or right actuation 24 V, 120 Vac, or 230 Vac LED E-stop and restart button 	<ul style="list-style-type: none"> Silver or gold plated contacts 24 V or 120 Vac LED E-stop 10-pin Brad Harrison connector 	<ul style="list-style-type: none"> Dual, left, or right actuation 24 V or 120 Vac LED Restart button

CABLE-PULL SAFETY SWITCH, 2CCP SERIES

Honeywell's MICRO SWITCH 2CCP Series Cable-Pull Safety Switch provides a readily accessible emergency stop signal along stretches of conveyors and machinery. A cost-effective means compared to using multiple emergency stop push-buttons. The 2CCP Series joins Honeywell's cable-pull safety switch portfolio that already includes the CPS Series of cable-pull products.

2CCP FEATURES	2CCP BENEFITS
Dual direction	Covers cable spans up to 500 ft. Fewer number of switches required per installation creates savings on unit and wiring costs.
Configurable platform	Many options available within one package size. 576 possible SKU combinations. Options for conduit ports, contacts, actuation direction, LED, E-stop, and restart button.
Direct-opening, snap-action contacts	Contacts are held closed when the actuating cable is under proper tension and the reset knob is set to the run position. Upon activation, a cam positively open the NC contacts. The snap-action operation causes the mechanical latch almost immediately.
Latches on both slackened and pulled cable	Provides tension loss monitoring due to wire breakage or thermal expansion.
Wide tolerance zone for cable tensioning	Protects against nuisance tripping and the effects of thermal expansion. $\pm 30^{\circ}\text{F}$ for cable runs up to 500 ft. Longer runs achievable at smaller temperature windows.
Integral reset mechanism	NC switch contacts remain open until the unit is reset by properly tensioning the cable and manually rotating the blue reset knob to "Run" condition following switch actuation.
Restart button	Equipment is not allowed to restart automatically after the cable-pull switch is reset. The integrated restart button can be used to send a signal back to the PLC for equipment start. This is in lieu of installing a local control station or using an existing HMI.
Improved LED	More light intensity and better side viewing ensures switch status can be seen easily from a distance. Available in 24 Vdc, 120 Vac, or 230 Vac.
E-stop button	Provides E-stop access even at the extreme ends of the span.
Replaceable front cover	Units with an E-stop are prone to damage. Impact-resistant plastic cover has been designed for fast and economic replacement. LED and restart button are mounted to base of unit and do not require replacement or rewiring.
Improved tension window	Magnified window and clear markings makes system setup and rope tension maintenance faster and more precise.
External mounting holes	Front cover does not need to be removed to access mounting holes creating easier installation and maintenance access.
Large wiring cavity with straight through wiring	Easier access to contact block allows for faster and simpler wiring.
Optional rear conduit port	Option to route wiring through the back of the unit for easier installation and to eliminate looping cable.

CABLE-PULL SAFETY SWITCH, 2CCP SERIES

TABLE 1. SPECIFICATIONS

DESIGNATION AND UTILIZATION CATEGORY		RATED OPERATIONAL CURRENT IE (A) AT RATED OPERATIONAL VOLTAGE (V)		
		24 V	120 V	240 V
AC15 (Contact Rating)	A300	–	6 A	3 A
DC13 (Contact Rating)	Q300	2.8 A	0.55 A	0.27 A
Rated thermal current (Ith)		10 A		
Rated impulse withstand (Uimp)		2500 V		
Rated insulation voltage (Ui)		300 V		
Usable gold-plated current (if applicable)		1 mA to 50 mA, 60 Vdc max./125 Vac max.		
Shock		15 g		
Conditional short-circuit current		1000 A		
Sealing		IP54; NEMA 1		
Pollution code		3		
Operating temperature range		-40 °C to 85 °C [-40 °F to 185 °F]		
Short-circuit protective device (type/maximum rating)		Class J fuse (10 A/600 V)		
Vibration		10 Hz to 500 Hz, 5 g		
Mechanical life		375,000 operations		

Complies with:

- Low Voltage Directive 2014/35/EU, EMC Directive 2014/30/EU
- Machinery Directive 2006/42/EC only as the directives relate to the components being used in a safety function
- IEC/EN 60947-1, IEC/EN 60947-5-1, IEC/EN 60947-5-5
- EN ISO 13850 compliance
- UL Category NISD, Emergency Stop Devices

MCTF (Mechanical Life): >375,000 cycles with single-sided confidence limit of 100 %

MCTF (Electrical Life): >50,000 cycles with single-sided confidence limit of 87.5 %

Highest SIL Capability: SIL3 (HFT:1), IEC 61508-2

Proof Test Interval: 1 Year

FIGURE 1. PRODUCT NOMENCLATURE

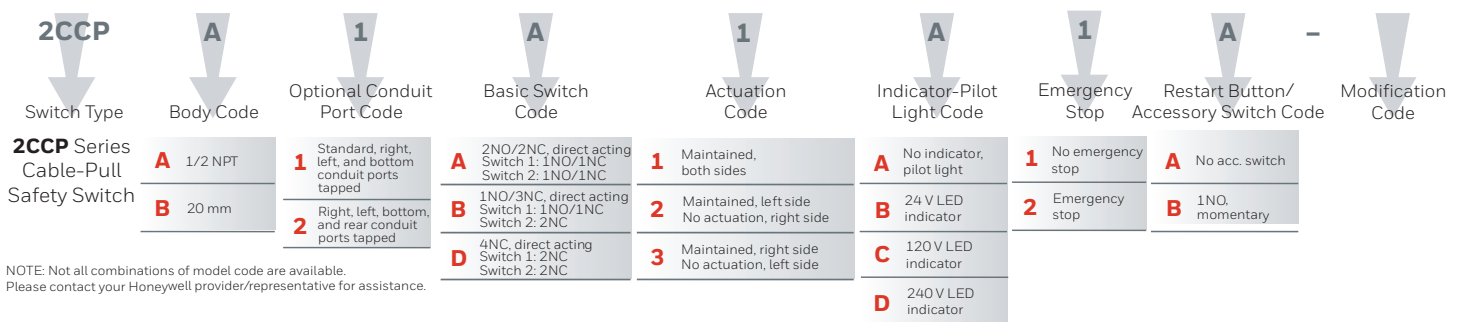

NOTE: Not all combinations of model code are available. Please contact your Honeywell provider/representative for assistance.

CABLE-PULL SAFETY SWITCH, 2CCP SERIES

FIGURE 2. MOUNTING DIMENSIONS

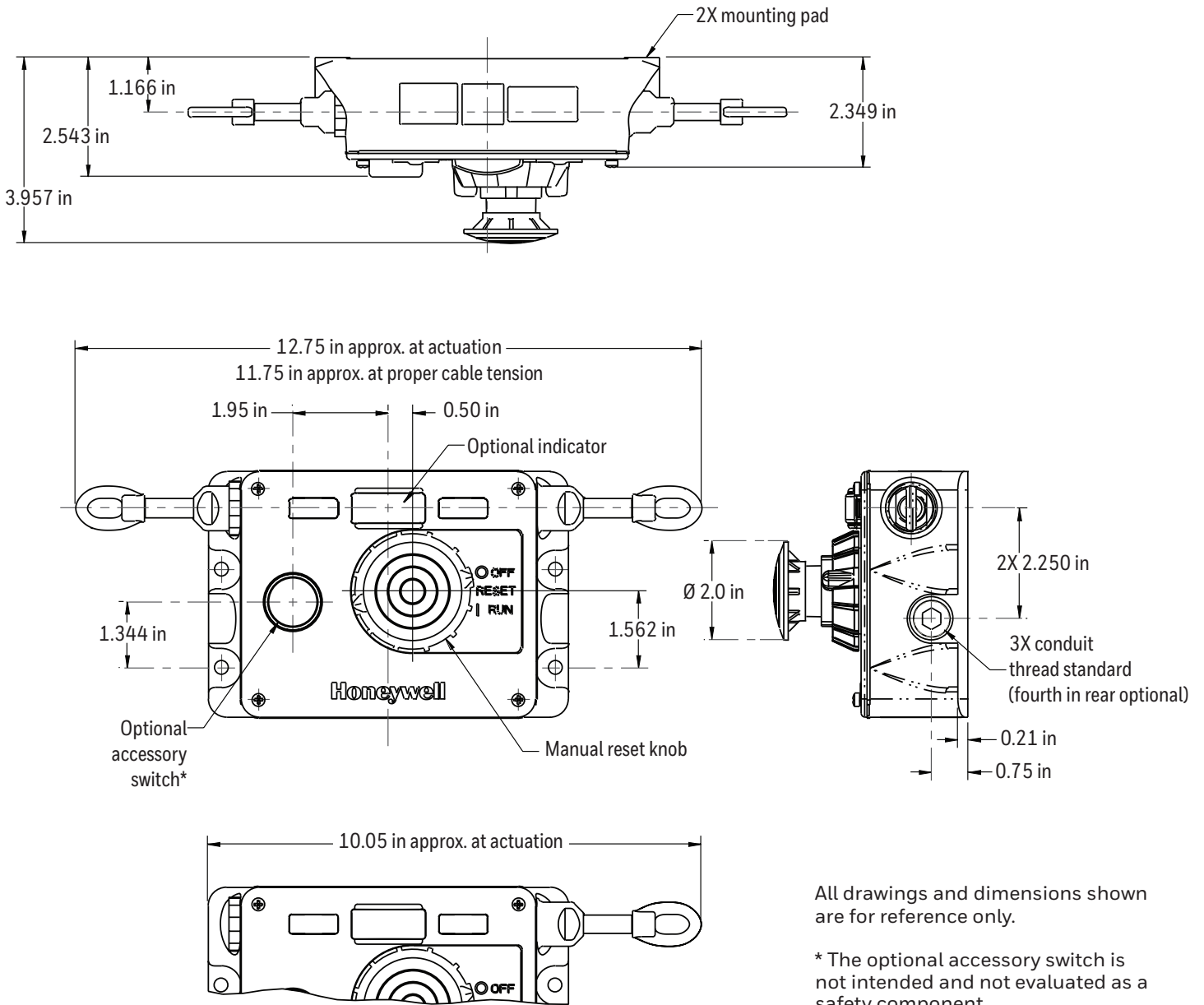

All drawings and dimensions shown are for reference only.

* The optional accessory switch is not intended and not evaluated as a safety component.

CABLE-PULL SAFETY SWITCH, 2CCP SERIES

FIGURE 3. CIRCUIT DIAGRAMS AND TRAVEL SPECIFICATIONS

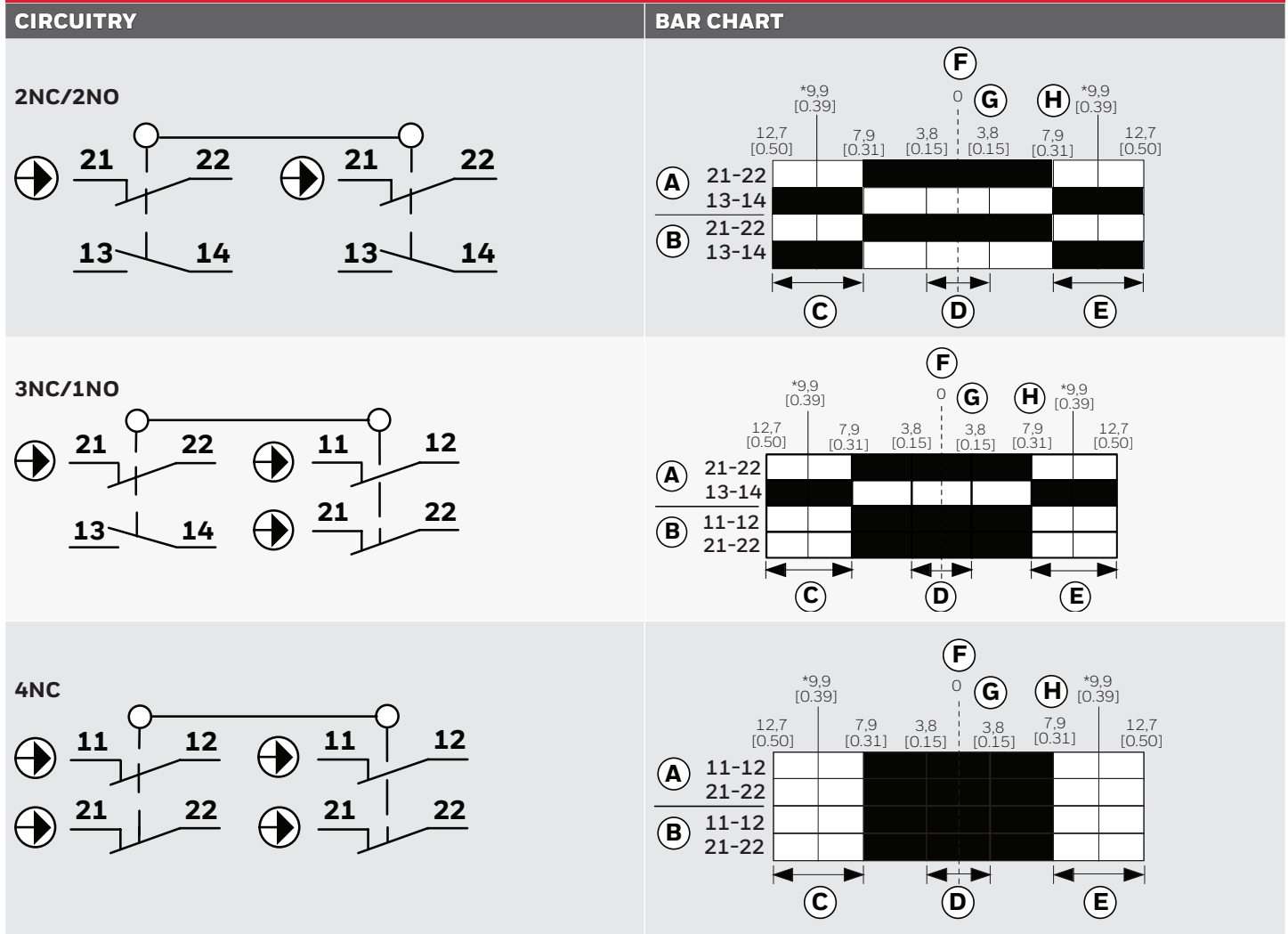

A = Left switch; B = Right switch; C = Slackened cable; D = Proper cable tension; E = Pulled cable; F = Cable tension 111 N [25 lb] G = Cable tension 133 N [30 lb]; H = Cable tension 178 N [40 lb]; ■ = contact closed; □ = contact open; *Positive opening action contact according to IEC/EN 60947-5-1

NOTE: All circuitry and bar charts are shown in switch “RUN” mode.

CABLE-PULL SAFETY SWITCH, 2CCP SERIES

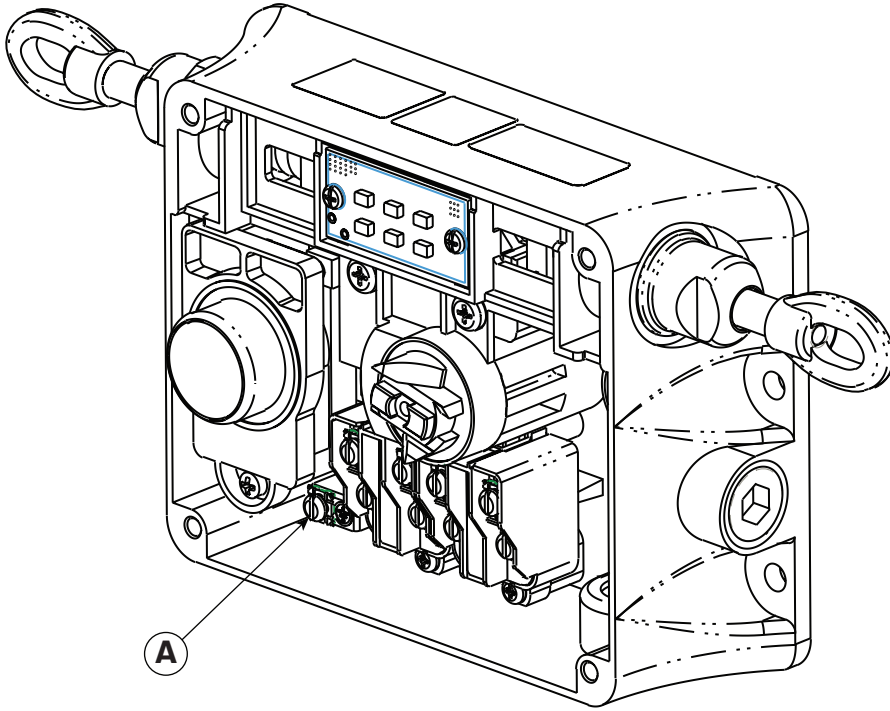
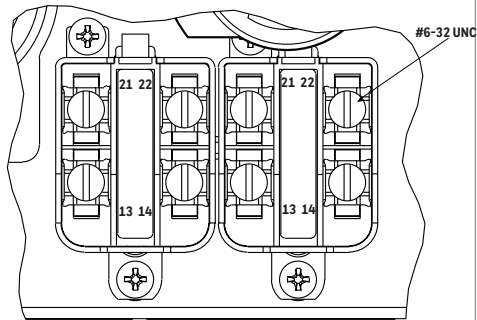
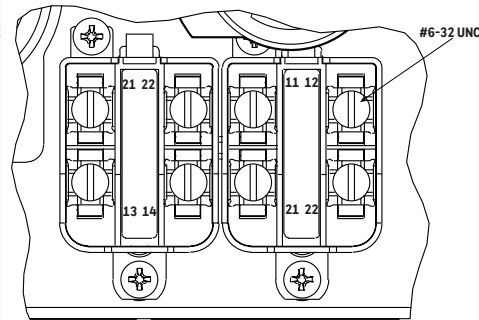

FIGURE 4. CONTACTS

2NC/2NO



3NC/1NO



4NC

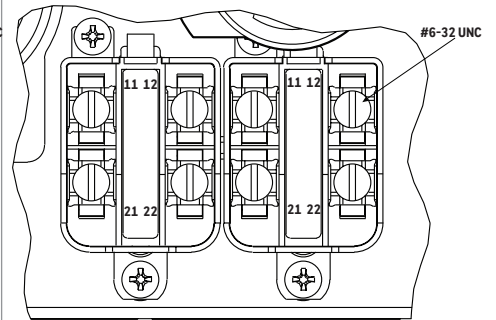

A = Grounding screw

CABLE-PULL SAFETY SWITCH, 2CCP SERIES

FIGURE 5. 2CCP SYSTEM COMPONENTS

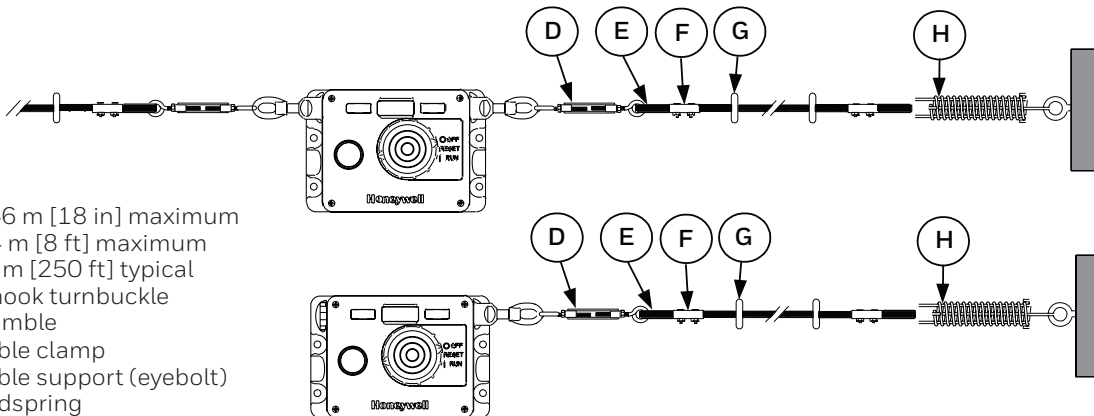
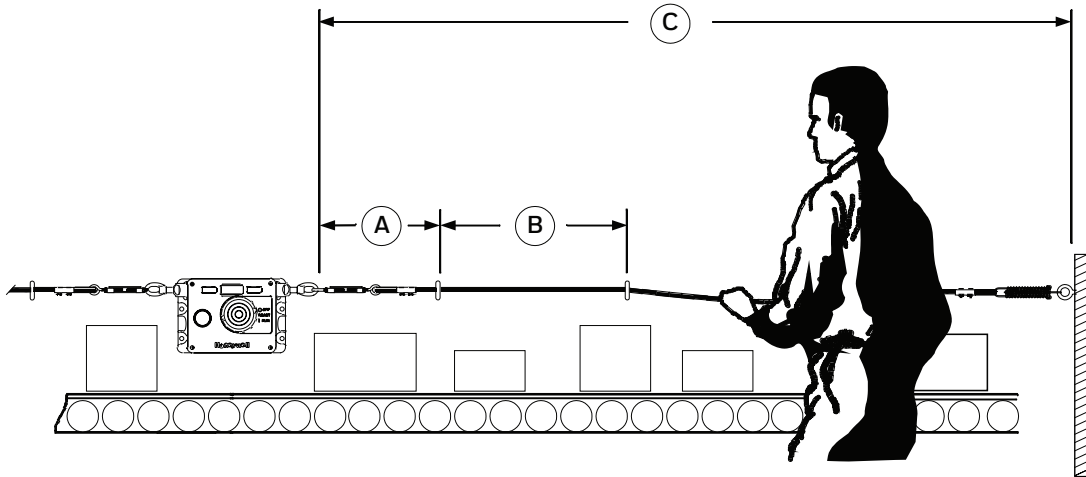

CABLE-PULL SAFETY SWITCH, 2CCP SERIES

FIGURE 6. 2CCP SWITCH COMPONENTS

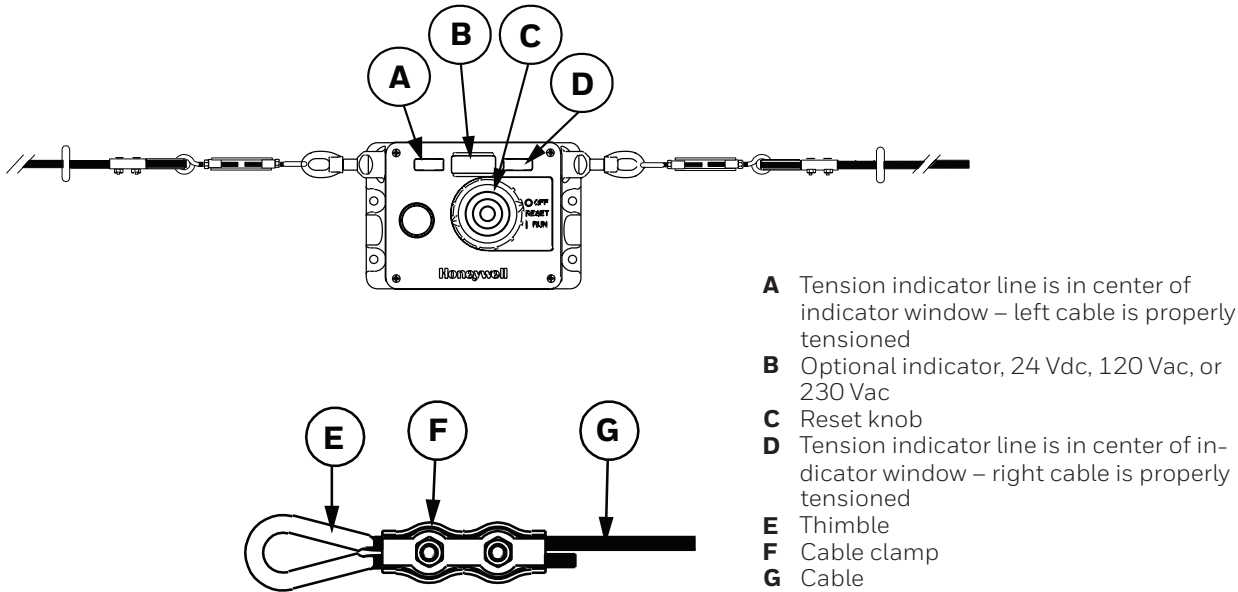

**TABLE 2. FUNCTIONAL SAFETY INFORMATION
RESULTS OF IEC 61508 FUNCTIONAL SAFETY ASSESSMENT**

Safety function: To open a normally closed switch contact when an actuating cable is pulled, the actuating cable is slackened or the E-Stop is depressed.		CABLE-PULL SAFETY SWITCH (2CCP SERIES)	
		1oo1	1oo2
Summary of IEC 61508-2 Clauses 7.4.2 and 7.4.4			
Architectural constraints & type of product A/B		HFT = 0, Type A	HFT = 1, Type A
Safe failure fraction (SFF)		70 %	70 %
Random hardware failures (h⁻¹)	λ_{DD}	0.00E+00	0.00E+00
	λ_{DU}	3.06E-07	3.06E-07
Random hardware failures (h⁻¹)	λ_{SD}	0.00E+00	0.00E+00
	λ_{SU}	7.17E-07	7.17E-07
Diagnostic coverage (DC)		0 %	0 %
PFD @ PTI = 8760 hrs., MTTR = 8 hrs.		1.34E-03	1.36E-04
Probability of dangerous failure (high demand - PFH) (h⁻¹)		3.06E-07	3.13E-08
Hardware safety integrity compliance		Route 1 _H	Route 1 _H
Systematic safety integrity compliance		Route 1 _S see report R70216114B	Route 1 _S see report R70216114B
Systematic capability (SC 1, SC 2, SC 3, SC 4)		SC 2	SC 2
Hardware safety integrity achieved		SIL 2	SIL 3

If product is used as HFT = 1, then IEC 61508-2 clause 7.4.3 should be considered.

Proof Test Interval: 1 Year

Functional Safety Procedure performed per Step 6 at Proof Test Interval

CABLE-PULL SAFETY SWITCH, 2CCP SERIES

TABLE 3. ACCESSORIES

LISTING	ACCESSORY (AVAILABLE SEPARATELY)
CLSZC1	7,6 m (25 ft) cable
CLSZC2	15,2 m (50 ft) cable
CLSZC3	30,5 m (100 ft) cable
CLSZC4	45,7 m (150 ft) cable
CLSZC5	61,0 m (200 ft) cable
CLSZC7	76,2 m (250 ft) cable
CLSZTC	<ul style="list-style-type: none"> • (2) Thimbles • (2) Low-profile duplex cable clamps
CPSZ1S	(1) Draw-bar endspring
CPSZK1	<ul style="list-style-type: none"> • (1) J-hook turnbuckle with lock nuts • (2) Thimbles • (2) Low-profile duplex cable clamps • (16) Sets of cable supports [(16) 1/4-20 eye bolts, (32) 1/4-20 nuts, (32) flat washers, (16) lock washers]
CPSZTB	(1) J-hook turnbuckle with lock nuts
CPS-BRACKET	(1) Mounting bracket
2CPZ-C1	(1) 2CCP replacement cover assembly with E-stop button for product without the optional accessory switch
2CPZ-C2	(1) 2CCP replacement cover assembly with E-stop button and indicator for product with the optional accessory switch
2CPZ-LED24	Accessory LED PCBA, 24 Vdc
2CPZ-LED120	Accessory LED PCBA, 120 Vac
2CPZ-LED240	Accessory LED PCBA, 240 Vac
CPSZPTSPCR-10	(10) Proper tension spacer

FOR MORE INFORMATION

Honeywell Sensing and Internet of Things services its customers through a worldwide network of sales offices and distributors. For application assistance, current specifications, pricing, or the nearest Authorized Distributor, visit sensing.honeywell.com or call:

USA/Canada	+302 613 4491
Latin America	+1 305 805 8188
Europe	+44 1344 238258
Japan	+81 (0) 3-6730-7152
Singapore	+65 6355 2828
Greater China	+86 4006396841

Honeywell Sensing and Internet of Things

830 East Arapaho Road
Richardson, TX 75081
sensing.honeywell.com

WARRANTY/REMEDY

Honeywell warrants goods of its manufacture as being free of defective materials and faulty workmanship during the applicable warranty period. Honeywell's standard product warranty applies unless agreed to otherwise by Honeywell in writing; please refer to your order acknowledgment or consult your local sales office for specific warranty details. If warranted goods are returned to Honeywell during the period of coverage, Honeywell will repair or replace, at its option, without charge those items that Honeywell, in its sole discretion, finds defective. **The foregoing is buyer's sole remedy and is in lieu of all other warranties, expressed or implied, including those of merchantability and fitness for a particular purpose. In no event shall Honeywell be liable for consequential, special, or indirect damages.**

While Honeywell may provide application assistance personally, through our literature and the Honeywell web site, it is buyer's sole responsibility to determine the suitability of the product in the application.

Specifications may change without notice. The information we supply is believed to be accurate and reliable as of this writing. However, Honeywell assumes no responsibility for its use.

⚠ WARNING IMPROPER INSTALLATION

- Consult with local safety agencies and their requirements when designing a machine-control link, interface and all control elements that affect safety.
- Strictly adhere to all installation instructions.

Failure to comply with these instructions could result in death or serious injury.

⚠ WARNING MISUSE OF DOCUMENTATION

- The information presented in this product sheet is for reference only. Do not use this document as a product installation guide.
- Complete installation, operation, and maintenance information is provided in the instructions supplied with each product.

Failure to comply with these instructions could result in death or serious injury.